

DBB ball valve specifications:

Design & manufacturer standard: ASME B16.34

Marking : MSS AP-25

Temperature: -29~150°C

Medium: water, oil & gas

Pressure test standard: API 598

Shell test (water): 4500psi

Seat seal test (water): 3300psi

Air test: 0.6Mpa

Material list

Bonnet: ASTM A105

O-Ring: VITON

Ball: SS304

Seat: PPL

Body: ASTM A105+ galvanized

Stem: A276 410

Thrust collar: PTFE

Pin: SS

Needle: A276 304

Nut: A276 304

Brief instruction of DBB ball valve:

DBB ball valve is a [double block and bleed valve](#). Double block and bleed and relief function valves are suitable for aviation kerosene, light oil, natural gas, liquefied gas, pipeline gas, chemical media and other pipelines, as an ideal device for cutting off media.

The key to the working principle of the double block and bleed and relief function valve is the action of the two sealing slides installed on the cock.

The valve has an automatic relief device (optional). After the valve is completely shut off, the valve cavity is prevented from abnormally increasing pressure and the effect of the valve is checked. The

valve switch indicator issynchronized with the switch position, which can accurately display the switchstatus of the valve.

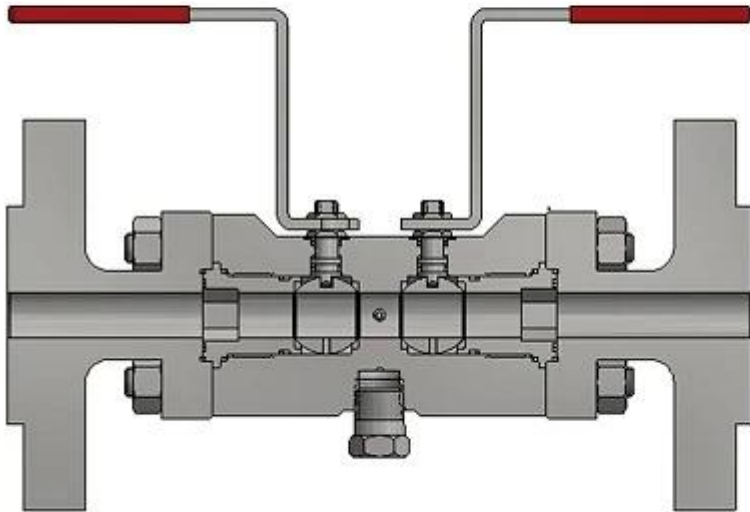

Other materials are available base on clients' requests.